

DESIGN NOTES

Monitor Network Compliant –48V Power Supplies – Design Note 290

Brendan Whelan

Introduction

Reliability is a top priority for the designers of modern telephone and communication equipment. Designers take extra care to protect circuitry from failure-causing temperature and voltage changes, employing redundancy whenever possible, especially for power supplies. The power supplies are monitored to obtain early warning of impending failure. Often complicated circuitry that can include a voltage reference, comparators, voltage regulator and several precision resistor dividers is used. Designers may also use discrete components to monitor and indicate the state of power supply fuses. The resulting circuitry can be expensive in terms of component cost, board space and engineering time. The LTC1921 replaces the complicated monitoring circuitry with a simple integrated precision monitoring system contained entirely in an 8-lead MSOP package.

Features

The LTC1921 is the only integrated solution that can monitor two independent –48V power supplies, plus associated fuses and drive up to three optoisolators or

LEDs to indicate status. The required external components are three resistors and optocouplers or LEDs, as shown by the simple circuit in Figure 1. The LTC1921 can withstand $\pm 100V$ DC at the supply and fuse input pins and tolerates $\pm 200V$ transients.

The LTC1921 monitors supply voltages by dividing the voltage internally and comparing to an internal precision reference. Since no critical precision external components are required, component cost, board space and design time are minimized while accuracy is maximized. The LTC1921 comes with telecom industry accepted preset voltage thresholds, including undervoltage ($-38.5V$), undervoltage recovery ($-43V$) and overvoltage ($-70V$). The overvoltage threshold has a 1.3V hysteresis that defines the overvoltage recovery threshold. These thresholds are trimmed to meet exacting requirements. This eliminates the messy worst-case threshold tolerance error calculation required when using discrete comparators, resistors and a separate voltage reference.

LTC and LT are registered trademarks of Linear Technology Corporation. Hot Swap is a trademark of Linear Technology Corporation.

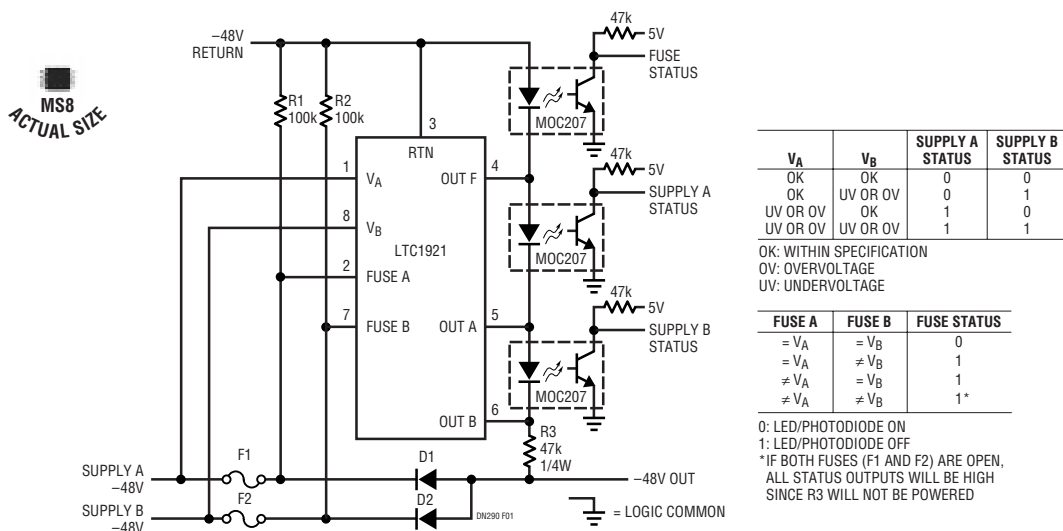

Figure 1. The LTC1921 Requires Few External Components for Monitoring Two Supplies

The LTC1921 is designed to indicate proper supply status across a wide variety of conditions. In order to accomplish this, the internal architecture is symmetrical. The LTC1921 is powered via the supply monitor input pins, V_A and V_B . Supply current can be drawn from either or both pins so the device can operate properly as long as one supply is within the operating range. Since power is not drawn from a combined supply (such as would be available with a diode OR), the LTC1921 will function properly even if the fuses or diodes are not functional. In addition, the LTC1921 has a low voltage lockout. If both supply voltages are very low, all three outputs of the LTC1921 lock into a fault indication state, thus communicating to supervisory systems that there is a problem even though there is not enough power for the LTC1921 to maintain accuracy.

The device monitors fuses by comparing the voltage potentials on each side of each fuse. If a significant difference (about 2V) is sensed, the LTC1921 signals that a fuse has opened. The voltage difference across the damaged fuse may be reduced by diode reverse leakage, making it difficult to detect a damaged fuse. Weak pull-up resistors (R1 and R2 in Figure 1) ensure that the LTC1921 can detect an open fuse circuit. The value of the pull-up resistors used is a function of the reverse leakage current of the OR'ing diodes used.

The LTC1921 can communicate supply and fuse status by controlling external optocouplers or LEDs. This allows for intelligent system monitoring despite high isolation voltage requirements. Control of the LEDs or optocouplers is accomplished by connecting the LTC1921 outputs in parallel with the LEDs or photodiodes. During normal supply and fuse conditions, the LTC1921 outputs are high impedance; current flows through the external diodes continuously. If a fuse opens or a supply voltage falls outside of the allowed window, then the proper LTC1921 output shunts the current around the diode, thus indicating a fault. *The outputs may be ORed to reduce the number of required optoisolators.*

Application Example

Figure 2 shows an LTC1921 and an LT[®]4250 Hot Swap[™] controller comprising a complete power system solution. The LTC1921 monitors both -48V supply inputs from the power bus, as well as the supply fuses. The status signals may be wired off the board via optoisolators to an isolated microprocessor or microcontroller to control system performance and warning functions. Resistors R9 and R10 pull up the fuse pins so that damaged fuses can be detected. The LT4250L controls the combined -48V supply during hot swapping and low supply conditions, and monitors the combined supply voltage. The PWRGD pin drives an optoisolator signalling the status of the LT4250's switched output.

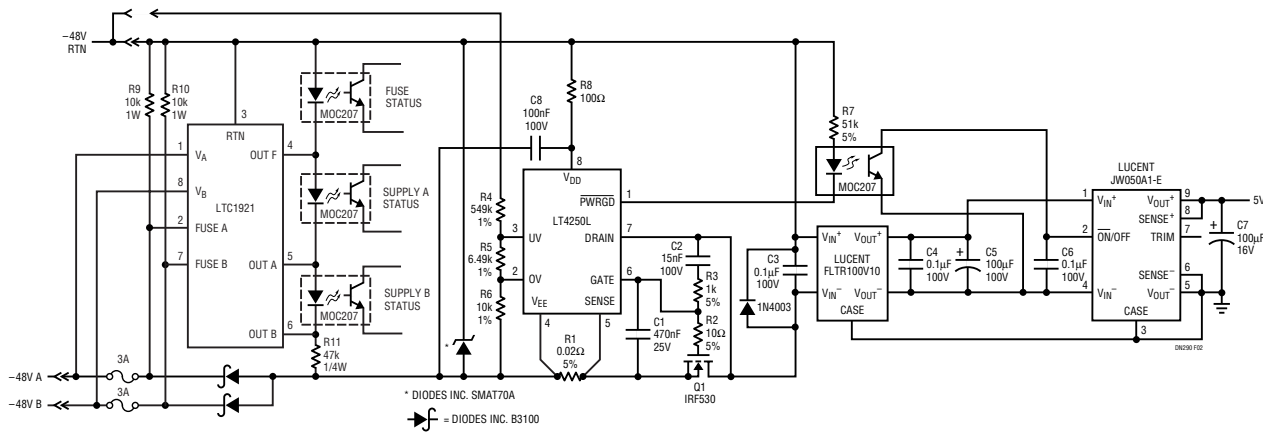

Figure 2. Network Switch Card Monitor with Hot Swap Control

Data Sheet Download

<http://www.linear.com/go/dnLTC1921>

For literature on our Supply Monitors, call **1-800-4-LINEAR**. For applications help, call (408) 432-1900, Ext. 2525